



*World Association of Floral Artists
India 2017 - 2020*



Grand Floral Affair 2020



**13TH WORLD FLOWER SHOW
24TH FEB - 1ST MARCH, 2020
JAIPUR, INDIA**

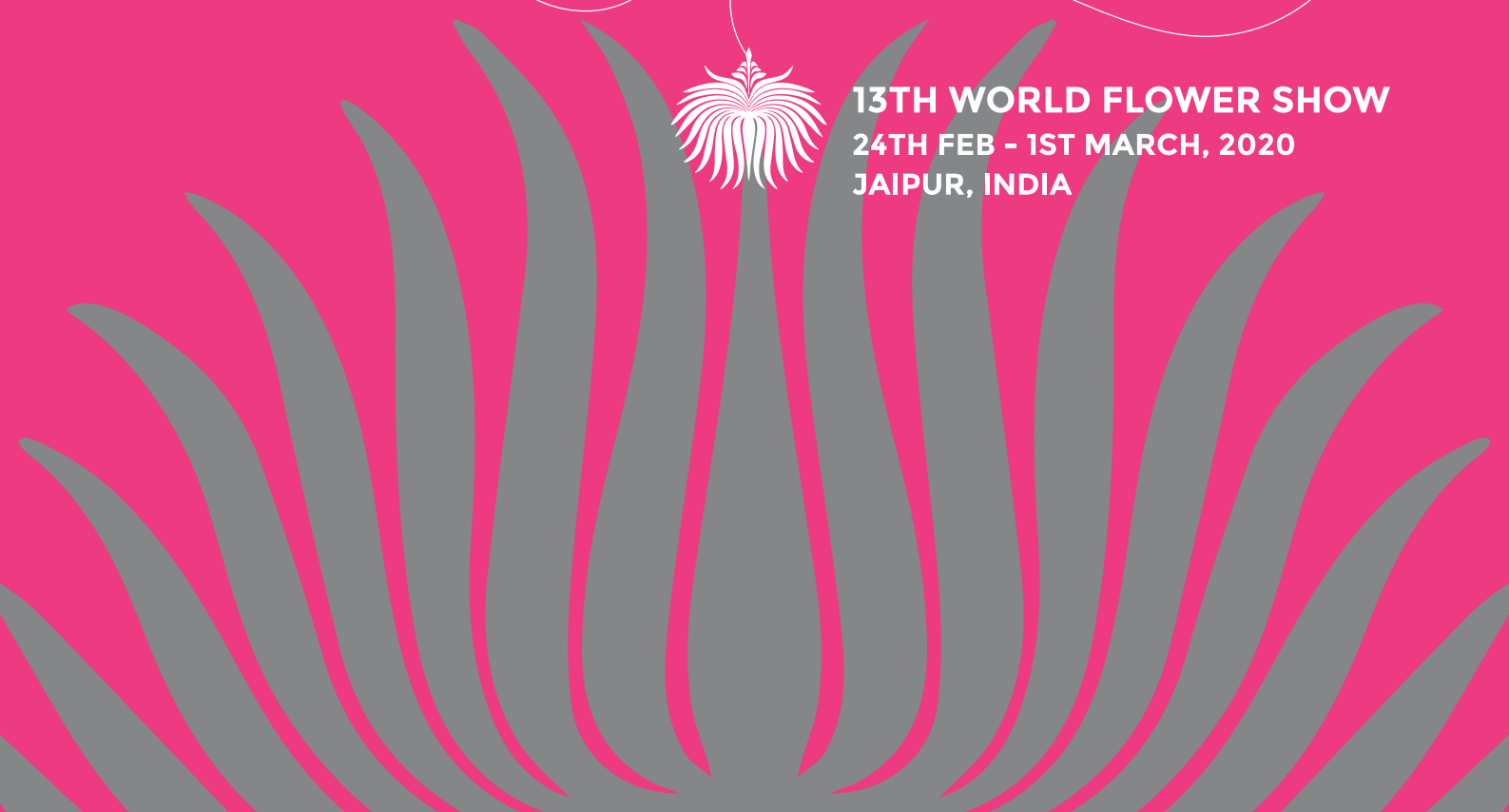



ABOUT WAFA

The World Association of Floral Artist (WAFA) is a not-for-profit organization of International floral art societies. The motto of the organization is to spread friendship through flowers.

CONTENTS

MESSAGE FROM THE PRESIDENT & SHOW CHAIR	01
MEMBER COUNTRIES	02
Wafa India Seminar	03
SUCCESS STORY	04
ITINERARY	05-06
REGISTRATION DETAILS	07
COMPETITION DETAIL	08
STAGING REGULATION	09
INTERNATIONAL WORLD FLOWER SHOW RULES	10
PLANT MATERIAL INFORMATION	11
DEMONSTRATION	12
WORKSHOPS	13
EXHIBITION HALL LAYOUT	14
CLASS DESCRIPTION	15-24
HONORARY EXHIBIT	25
HOTEL & TRAVEL INFORMATION	26



COMMITTEE MEMBERS

STANDING (L TO R)

SARITA CHHAWCHHARIA
MITA KANORIA
BHAWANI BANSAL
AVANTIKA GUPTA
PARUL SWARUP

JUNIOR SECTION
SEMINAR CHAIR
DEMOS, TALKS & WORKSHOPS CHAIR
PUBLICITY CHAIR
COMPETITIONS SECRETARY

SITTING (L TO R)

ALKA GUPTA
MANJARI BAGARIA
KAVITA PODDAR
LILY MORE
KAMLA PODDAR

TREASURER
VICE PRESIDENT
PRESIDENT
SECRETARY
SHOW CHAIR

MESSAGE FROM THE Wafa PRESIDENT



The Wafa India team eagerly awaits your arrival in our country! We look forward to 'Spreading friendship through flowers', as flower arrangers and visitors gather from around the world for the Grand Floral Affair - 13th World Flower Show.

We have put in our best to plan an interesting and wonderful schedule of classes which will bring out the best in creativity and styles of floral art. Alongside this, our team is working tirelessly to give you a taste of the Indian culture and local crafts through a variety of activities, demonstrations and workshops. The 'Pink City' will provide the perfect stage for showcasing the colours and traditions of India making this a very special and memorable experience for all!

- KAVITA PODDAR

MESSAGE FROM THE Wafa SHOW CHAIR



"PADHARO MHARE DESH"

Welcome to our Land, India - The land whose cultural diversity and heritage speaks for itself.

It gives me immense pleasure to welcome you to the 13th World Flower Show - The Grand Floral Affair 2020 - in Rajasthan, the land of Maharajas where royalty is the way of living, where celebrations know no boundaries and where the most exuberant colours match its vibrant culture. We have tried to blend the eternal beauty of flowers with the rich cultural ethos of Rajasthan to make it an experience to remember.

Our scriptures state "ATITHI DEVO BHAVA" - a guest is equivalent to God. In keeping with this tradition, we await your august presence at the Diggi Palace in the heart of the Pink City, Jaipur.

"KHAMMA GHANI" - Welcome

- KAMLA PODDAR

MEMBER COUNTRIES

Honorary Exhibits to be put up by 31 Countries

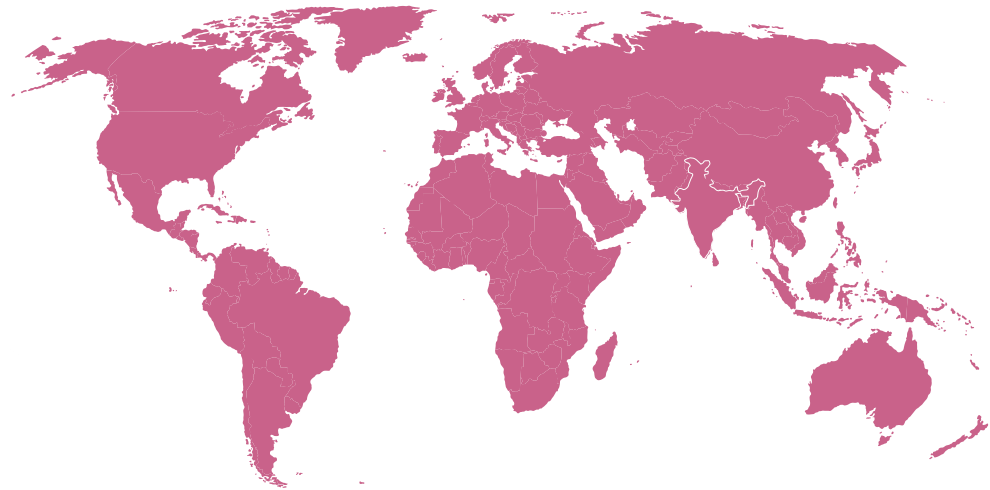

Map is Indicative

	Argentina		Malta
	Australia		Mexico
	Barbados		Netherlands
	Belgium		New Zealand
	Bermuda		Oman
	Brazil		Pakistan
	Canada		Peru
	France		Russia
	Hong Kong		South Africa
	India		Switzerland
	Ireland		Trinidad and Tobago
	Italy		United Kingdom
	Jamaica		United States of America
	Japan		Uruguay
	Kenya		Zimbabwe
	Korea		



WAFI INDIA SEMINAR

The last seminar in India was held in 2018, promoting the Grand Floral Affair to a huge extent. It was attended by 135 participants from 17 countries over a week. It got fantastic reviews in Hyderabad and Kochi.





Vinita Khemka

SUCCESS STORY

In Ireland 2014, the event had over 850 registrations. In Barbados 2017, it had over 350 registrations. India won “Best in Show” at the 11th World Flower Show in Ireland and 12th in Barbados.

WORLD FLOWER SHOWS

The events are held at an interval of three years, exclusively reserved to the members of WAFA. The first event was held at United Kingdom in the year 1981. The last one was at Barbados. All the events promotes the exchange of information concerning floral art. Moreover, the events encouraged, stimulated and promoted the participation in the art of floral design and to appreciate the cultural values.



Renu Poddar

WAFA SHOW 2020 ITINERARY

24TH FEBRUARY

9:00 am - 6:00 pm	Registration & collection of pre-ordered material
-------------------	---

25TH FEBRUARY

9:00 am - 6:00 pm	Registration & collection of pre-ordered material
-------------------	---

9:00 am - 3:00 pm	Staging of International Honorary exhibits
-------------------	--

10:00 am - 4:00 pm	Judges Briefing Seminar
--------------------	-------------------------

10:00 am - 7:00 pm	Vendors Market & Food Court
--------------------	-----------------------------

11:00 am - 3:00 pm	Receipt of Mail-in-Class
--------------------	--------------------------

4:00 pm - 6:00 pm	Competitors deposit staging materials
-------------------	---------------------------------------

5:00 pm - 8:00 pm	WAFA Seminar 2018 Reunion
-------------------	---------------------------

26TH FEBRUARY

6:00 am - 12:00 noon	Staging of Competitive Exhibits
----------------------	---------------------------------

8:00 am - 12:00 noon	Staging of Imposed Class
----------------------	--------------------------

9:00 am - 12:00 noon	Registration continues
----------------------	------------------------

10:00 am - 7:00 pm	Vendors Market & Food Court
--------------------	-----------------------------

11:00 am - 12:00 noon	Judges Luncheon
-----------------------	-----------------

1:00 pm - 6:00 pm	Judging of Competitions
-------------------	-------------------------

7:00 pm - 9:00 pm	Opening Ceremony
-------------------	------------------

27TH FEBRUARY

7:00 am - 9:00 am	Maintenance of Exhibits
-------------------	-------------------------

9:00 am - 11:00 am	Competitors/Judges Session
--------------------	----------------------------

10:00 am - 7:00 pm	Public Viewing - Grand Floral Affair
--------------------	--------------------------------------

10:00 am - 7:00 pm	Vendors Market & Food Court
--------------------	-----------------------------

10:00 am - 12:30 pm	Pre-booked demos & workshops at 2 hourly intervals
---------------------	--

4:00 pm - 7:00 pm	Awards Ceremony
-------------------	-----------------

WAFASHOW 2020 ITINERARY

28TH FEBRUARY	
7:00 am - 9:00 am	Maintenance of Exhibits
10:00 am - 7:00 pm	Public Viewing - Grand Floral Affair
10:00 am - 7:00 pm	Vendors Market & Food Court
10:00 am - 6:00 pm	Pre-booked demos & workshops at 2 hourly intervals

29TH FEBRUARY	
7:00 am - 9:00 am	Maintenance of Exhibits
10:00 am - 7:00 pm	Public Viewing - Grand Floral Affair
10:00 am - 7:00 pm	Vendors Market & Food Court
10:00 am - 4:30 pm	Pre-booked demos & workshops at 2 hourly intervals
10:00 am - 3:00 pm	WAFAGeneral Assembly
7:00 pm - 10:00 pm	Gala Dinner

1ST MARCH	
7:00 am - 9:00 am	Maintenance of Exhibits
10:00 am - 7:00 pm	Public Viewing - Grand Floral Affair
10:00 am - 7:00 pm	Vendors Market & Food Court
10:00 am - 4:30 pm	Pre-booked demos & workshops at 2 hourly intervals
7:00 pm	Closing of Show
5:30 pm - 7:30 pm	Dismantling of Exhibits

NOTES

Only registered delegates will have access to all paid events.

VENUE

Diggi Palace, Diggi House
Shivaji Marg, Panch Batti
Sangram Colony, C - scheme
Jaipur, Rajasthan

For any queries, please feel free to write to us at wafaindia2020@mapsor.com

Events may be subject to change due to unforeseen circumstances.



REGISTRATION DETAILS

1. Registrations will open on 1st April 2019. The registration forms will be available online at www.HoptheQue.com wherein you will be able to select the category you want to register in. Registration is open to all. Competitors must register.
2. Registration fees must be paid at the time of online registration. Please retain a copy for your records.
3. Only Registrants will be given access to tickets for events.
4. All costs must be paid in Indian Rupees.
5. Please make a copy for your own record.
6. Personal insurance against cancellation is recommended. Wafa India will not be liable for any loss arising due to change or cancellation of an event, of personal belongings and/or damage to property.

Last Date of Registration has been extended to **31st August**

Last Date of Registration (for competitors) has been extended to **31st July**

GOLD REGISTRATION (Rs. 35,000/-)

1. Season ticket (4 days) entry to the show.
2. Access to tickets for show events.
3. Access to Wafa Lounge.
4. Wafa India floral art book.
5. Show Brochure.
6. Post show E-brochure.
7. Official name badge.
8. Conference bag (welcome kit).
9. Opening ceremony & preview.
10. Awards ceremony.
11. Gala Dinner.

SILVER REGISTRATION (Rs. 25,000/-)

1. Season ticket (4 days) entry to the show.
2. Access to tickets for show events.
3. Access to Wafa Lounge.
4. Wafa India floral art book.
5. Show Brochure.
6. Post show E-brochure.
7. Official name badge.
8. Conference bag (welcome kit).
9. Awards ceremony.

PHOTOGRAPHY

The official photographer will automatically photograph FIRST, SECOND and THIRD prize, special award winners and honorary exhibits. Copies will be available for purchase at the show.

Only hand-held cameras may be used, without separate lighting, tripods or other supports.

COMPETITION DETAILS



1. All competitors must register. Exceptions: Mail-in class Competitors not attending the show.
2. Competitive classes are open to individual exhibitors who are members of a floral art society/national association represented in WAFA.
3. Closing date for Competition entries is 31 July 2019.
4. Accepted entries will be notified by First Week of August.
5. Re-confirmation of entry by competitor is due by 31 August 2019.
6. A competitor may take place in more than one class. Please indicate 1st, 2nd and 3rd choice on the application form.
7. For Imposed classes, participants are required to pay Rs. 11,000/- in addition to the Registration Fee.
8. Mail-in class participants are not required to pay the Registration Fee but are required to pay a Competitors entry fee of Rs. 5000/-.



STAGING REGULATIONS

Competitors unable to fulfill their commitments must notify the WFA India secretariat in advance of the show. There will be no refund of the Registration Fee, Competition Entry Fee, imposed or mail-in classes.

1. All competitive classes (Except: Mail-in classes) must be staged in situ by the competitor, who must use the specification given in the particular class.
2. Competitors may use pre-constructed or pre-woven plant material but it may not be a dominant component of the exhibit. Items requiring special time or expertise for their preparation may be brought ready assembled for incorporation in any exhibit, but may not dominate.
3. Competitors' badges **MUST** be worn at all times.
4. Only competitors and officials will be allowed in the halls during staging times.
5. All exhibits will be staged in artificial lighting. The staging time for competitive exhibits will be enforced from 6:00am - 12 noon.
6. Imposed class competitors, classes **MUST** stage their entries from 8:00am - 12 noon. Information to be supplied when accepted into class.
7. No help may be given regarding preparation or construction of an exhibit (except if required to lift a heavy object, and only then at the discretion of a show official).
8. All exhibits must be staged within the space provided, using the specified staging, unless otherwise indicated in the schedule. Attachments to and moving of staging is not permitted.
9. Competitors must place their waste material in bags provided by the show committee and remove it from the hall.
10. Aerosol / spray painting is **NOT** permitted in the halls.
11. For competitors wishing to use electrical equipment, please note that the supply is 220 W.
12. Judging will be conducted on Wednesday, 26th February 2020 at 1:00pm - 6:00pm. It will be conducted according to the international world show rules and regulations mentioned in this brochure.
13. No persons other than the judges, their stewards and the show officials will be permitted in the halls whilst judging is in progress.
14. In addition to Special Awards, prizes will be presented to first, second and third in each class.
15. The judges will be available for informal discussions between 9:00am - 11:00am on Thursday, 27th February 2020.

16. The decision of the judges' panel will be final.
17. Competitors are required to maintain their exhibits in prime condition for the duration of the show. Maintenance of exhibits may be carried out from 7:00am - 9:00am every morning. The Committee reserves the right to change or remove faded plant material.
18. All competitors property is at their own risk and they must be responsible for their own insurance, if deemed necessary. The World Association of Floral Artists India (WAFA) do not accept any liability for loss or damage to any of the competitors' property.
19. To ensure security of competitors and their property, the halls will be vacated completely from 5:30pm - 7:30pm on 1st March, except for members of WAFA India Show Committee. Competitors wearing badges will be admitted at 5:30pm. Any exhibits or parts thereof remaining unattended in the halls after 7:30pm will be deemed abandoned and will be disposed of.

Please note: Agreement to the above regulations is declared by completing the Registration Form.

FOR QUERIES PLEASE CONTACT: wafaindia2020@mapsor.com

INTERNATIONAL WORLD FLOWER SHOW RULES



1. An exhibit is made of plant material, with or without accessories, within the space specified in the show schedule.
2. Plant material must predominate over all other components of the exhibit.
3. The use of artificial plant material is forbidden unless otherwise stated in the schedule.
4. Painted and/or artificially coloured plant material may be used unless otherwise stated in the schedule.
5. Fresh plant material must be in water or in water-retaining material unless such material remains turgid till judging and must be maintained throughout the event.
6. Pre- prepared work must not predominate in an exhibit. Items requiring special time and expertise for their preparation may be brought ready assembled for incorporation in an exhibit but must not predominate.



PLANT MATERIAL INFORMATION

1. Any dried plant material or organic material goods carried into or shipped to **India** will need your own country's official Phytosanitary Certificate.
2. As soon as possible, the website will include names and advertisements of wholesalers who are willing to deal directly with exhibitors, take orders and arrange for pick up or delivery.
3. Plant material and buckets may be pre-ordered
4. Plant importation - Please visit the following link:
<http://plantquarantineindia.nic.in/PQISMain/Default.aspx>
Dried, skeletonized, glycerined, bleached, additionally coloured and manipulated plant material is considered natural.
5. Definition: Foliage
The Leaves of any plant.
Immature, unopened buds NOT showing petal colour.
Flowerless bracts are acceptable but they should NOT predominate in exhibits where there is a requirement to feature foliage.
Also flowerless grasses, equisetum, cacti/succulents, lichens, moss
This definition may not necessarily be botanically correct but it should be accepted for the purposes of this competitive show.



THE ROYAL INDIAN WEDDING

Indian weddings are rich with customs and rituals. Luxurious floral art is used lavishly in pre and post wedding ceremonies that are often spread over several days.

Lets experience the wonderful demonstrations on Indian Wedding which will include delightful sights, melodious sounds, spicy tangy Indian tastes, and the fragrance of Indian flowers. Immerse yourself in this extravagant affair.

DATE: 28th FEB | **TIME:** 4:00pm - 6:00pm | **CHARGE:** Rs. 4,500/-

PHOOL BANGLA (HOUSE OF FLOWERS)

The tradition of Phool Bangla was started to give respite to the lord from the heat by making floral ornaments, garments and flower thrones. The elaborate flower decorations are very attractive and bring many people to the temple to admire them. The buds and flowers which are ephemeral and specific to tropical origin (.Mogra, Tagar and Bela) are used with the leaves to make the ornaments, Phool Bangla and garments.

A rare opportunity to experience the same, being created and come alive.

DATE: 29th FEB | **TIME:** 10:00am - 12:00 noon & 2:00pm - 4:00pm | **CHARGE:** Rs. 3,500/-

UNITY IN DIVERSITY

India is a uniquely diverse land where cultural differences are celebrated. From the Himalayas in the north to the Peninsula in the South, from the vast deserts in the West to the mighty Ganges in the East, India's heritage is unparalleled. We send spaceships to Mars while 70% of the population is dependent on farming. India is a land like no other.

We have worked very hard to showcase this diversity to you through various floral activities unique to our country and its four primary regions. Join us for demonstrations by our artisan and revel in the beauty of our land.

DATE: 1st MAR | **TIME:** 10:00am - 12:00 noon & 2:00pm - 4:00pm | **CHARGE:** Rs. 3,500/-

ALL DEMOS WILL BE FOLLOWED BY LIGHT SNACKS,TEA AND COFFEE

WORK SHOPS



MAKE YOUR HANDMADE PAPER

Every piece of HANDMADE PAPER is unique to its maker. Contemporary artists make paper to use it as a material for sculptures, even as an art piece on its own, and also in many flower arrangements. Let's learn and enjoy the art of this handmade paper making. And adorn it with the flowers provided.

DATE: 27th FEB & 28th FEB | **TIME:** 10:00am - 12:30pm | **CHARGE:** Rs. 3,500/-

BANDHANWAR (DOOR HANGING)

Guest is considered God in Indian culture. To welcome him, "Bandhanwar" is used to decorate the main entrance. In this workshop, we will be making a decorative door hanging with a combination of traditional materials unique to India such as shoal, gota and jute.

DATE: 29th FEB | **TIME:** 10:00am - 12:30pm & 2:00pm - 4:30pm | **CHARGE:** Rs. 3,500/-

JEWELLERY MAKING

Flowers have been an integral part of our Indian celebrations. India has its own unique style of making floral ornaments and jewellery for festivals or weddings. Fresh flower jewellery always brings with it, a special energy and feel. In this workshop, we will try our hands in making garlands and ornaments. The traditional as well as the contemporary styles.

DATE: 1st MAR | **TIME:** 10:00am - 12:30pm & 2:00pm - 4:30pm | **CHARGE:** Rs. 3,500/-

ALL WORKSHOPS WILL BE FOLLOWED BY LIGHT SNACKS, TEA AND COFFEE

EXHIBITION HALL LAYOUT

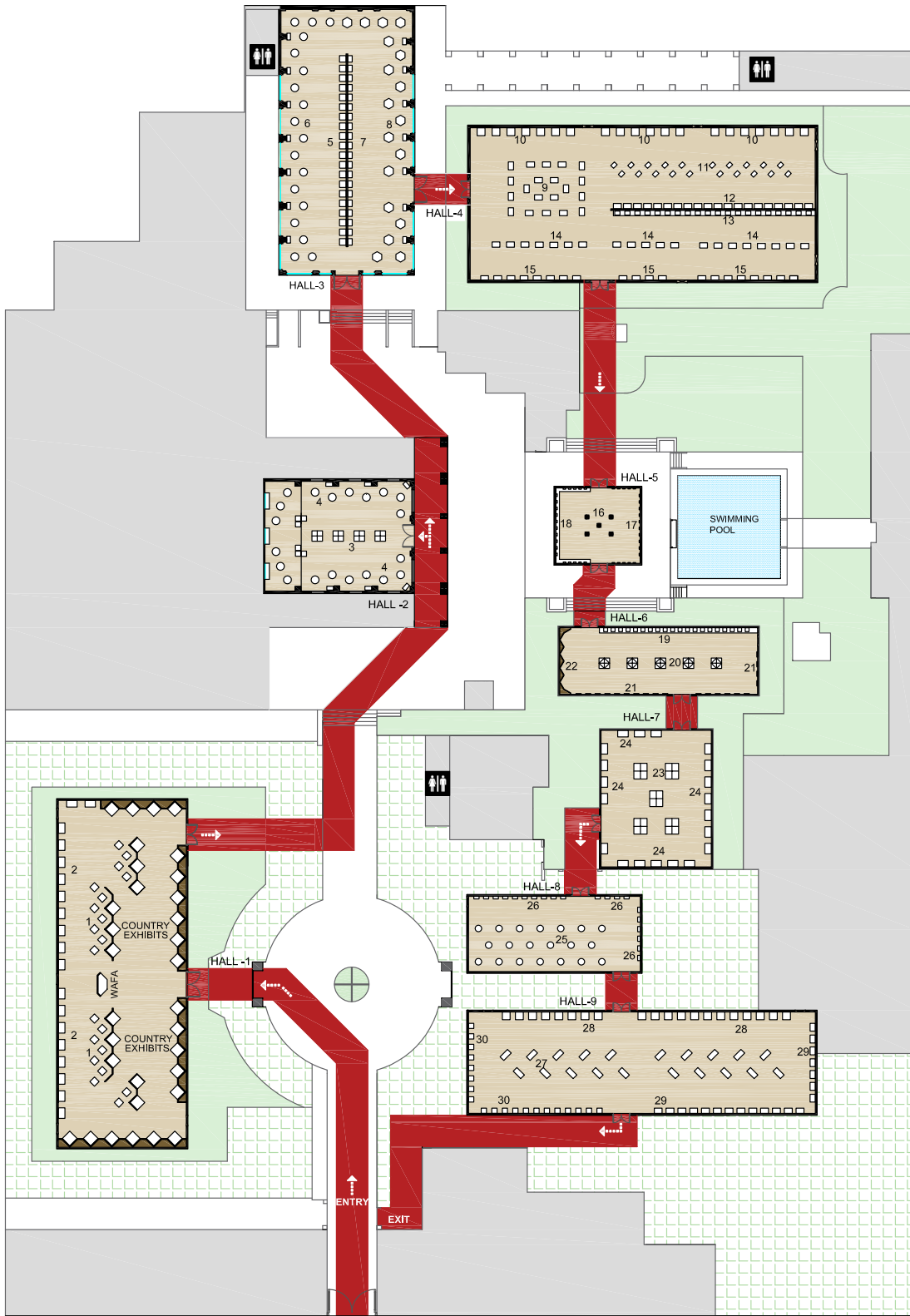

MAIN GATE

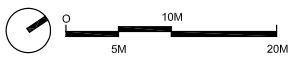

PLAN

PANTONE SHADE	
SILVER GREY (PANTONE 14-0000 TPG)	
CREME BRULEE (PANTONE 13-1006 TPG)	



1 BROKEN LINES

Imposed class for 2 person team

Space allowed

Width : 75 cm

Depth : 75 cm

Height : Optional

Staging : A base 1.9 cm thick, width 75 cm and depth 75 cm.

Colour : Creme Brulee (Pantone 13-1006 TPG)

Viewed and judged from all around.

Open to WAFA and non WAFA members.

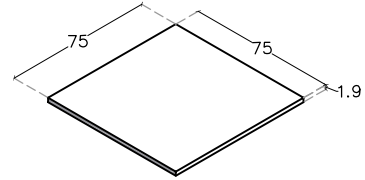

2 HUSTLE & BUSTLE

An exhibit for an individual or for 2 person team

Space allowed

Width : 120 cm

Depth : 75 cm

Height : 180 cm

Staging : A base 1.9 cm thick. Two movable crates of pinewood painted in black are provided.

Crate 1 : Width : 60 cm

Crate 2 : Width : 45 cm

Depth : 35 cm

Depth : 30 cm

Height: 20.5 cm

Height: 20.5 cm

Space in between the planks of the crate is 2 cm.

Colour : Background and base is Creme Brulee (Pantone 13-1006 TPG)

Viewed and judged from front.

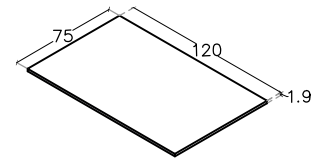
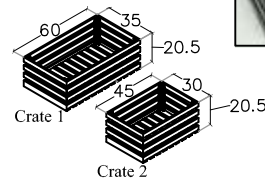

3 THE MAHARAJA'S JEWEL

Craft Mail-In-Class

Space allowed

Width : 45 cm

Depth : 45 cm

Height : 70 cm

Staging : Tabling 75 cm from the floor. A turban with circumference 68 cm approx and varying height from approx 10 - 13 cm. To be placed on a stand of height 45 cm.

Colour of turban : Golden

Iron stand : Black

Table : Black

Background : Black

Maximum weight on turban : 1 kg

Viewed and judged from three sides

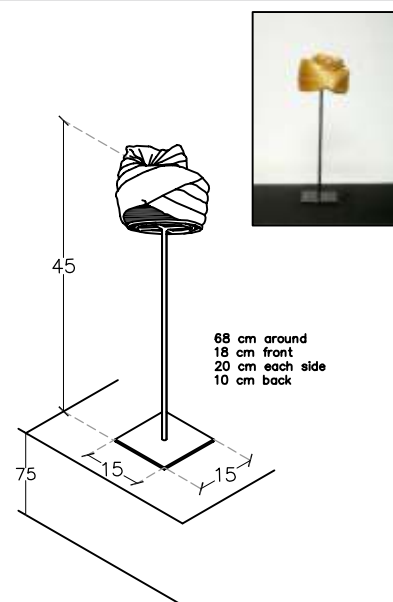

Open to WAFA and non WAFA members. To be brought in or mailed ready for staging by the show committee.

Exhibit to be sent attached with pins or hooks for staging along with marked display points.

4 REELS & ROLLS

An exhibit

Space allowed

Diameter : 90 cm

Height : Optional

Staging : A plinth with base of 30 cm X 30 cm & height of 45 cm with circular top of 90 cm diameter.

Two moveable wire mesh cylinders are provided.

Cylinder 1 : Diameter : 20 cm

Cylinder 2 : Diameter : 20 cm

Height : 45 cm

Height : 55 cm

Mesh square size : 2.5 cm

Cylinder Colour : Black

Table : Black

Viewed and judged from all around

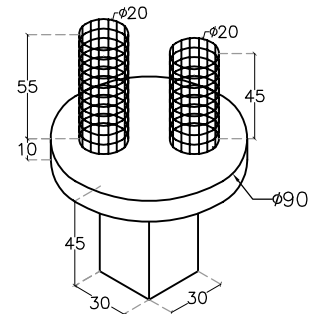

5 MAGNIFICENT MUGHALS

An exhibit

Space allowed

Width : 75 cm

Depth : 85 cm

Height overall : 180 cm

Staging : Tabling 75 cm from the floor having a depth of 75 cm. A black, hollow bust is provided with a height of 60 cm, width of 45 cm and depth of 20 cm. The face being 23 cm. The design may come over the front of the table by 10 cm.

Colour : Backdrop and tabling is Creme Brulee (Pantone 13-1006 TPG)

Viewed and judged from the front.

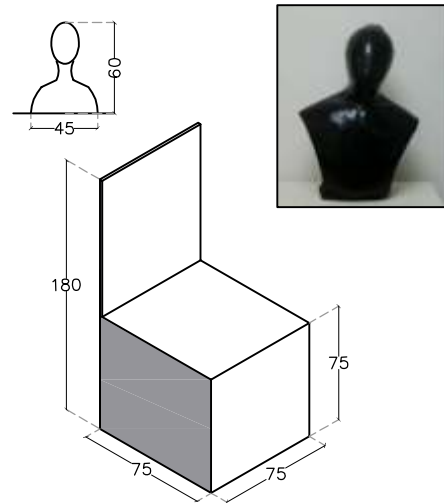

6 VERTICAL TWIST

An exhibit

Space allowed

Diameter : 90 cm

Height : optional

Staging : 90 cm round base, 1.9 cm thick.

Colour : Black

Viewed and judged from all around.

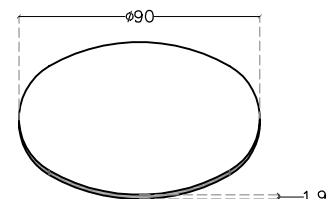

7 PIECE BY PIECE

A pave exhibit

Space allowed

Width : 75 cm

Depth : 50 cm

Height overall : 65 cm

Staging : Tabling 50cm from the floor.

Colour : Creme Brulee (Pantone 13-1006 TPG)

Viewed and judged from front and top

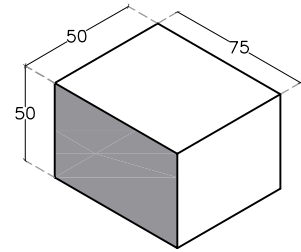

8 RUGGED SPLENDOUR

A floor exhibit

Space allowed

Each side : 60 cm

Height : Optional

Staging : A hexagon base 1.9 cm thick, each side being 60 cm

Colour : Black

Viewed and judged from all round.

Open to WAFA and non WAFA members.

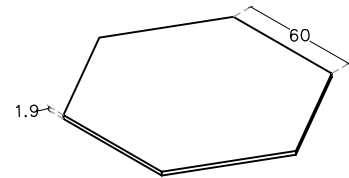

9 POMP & FEST

An exhibit : A table for celebration

Space allowed

Width : 90 cm

Depth : 60 cm

Height : Optional

Staging : A plinth width 60 cm, depth 45 cm, height 75 cm with a top of width 90 cm, depth 60 cm, thickness 1.9 cm.

Colour : Silver Grey (Pantone 14-0000 TPG)

Viewed and judged from the front.

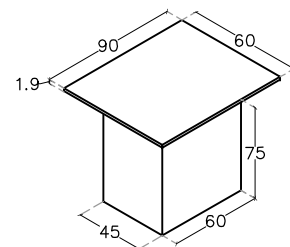

10 MUSIC FOR THE SENSES

A Pedestal Exhibit

Space allowed

Width : 90 cm

Depth : 90 cm

Height : 240 cm

Staging : A base 1.9 cm on the floor. A pedestal of height 90 cm, width 30 cm, depth 30 cm to be placed anywhere on the base.

Colour : Backdrop, base and pedestal is Silver Grey (Pantone 14-0000 TPG)

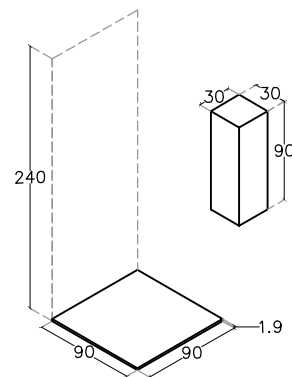

Viewed and judged from the front

11 IN PEACEFUL CONTEMPLATION

An exhibit

Space allowed

Width : 60 cm

Depth : 45 cm

Height : optional

Staging : Tabling 90 cm from the floor.

Colour : Silver Grey (Pantone 14-0000 TPG)

Viewed and judged from all around.

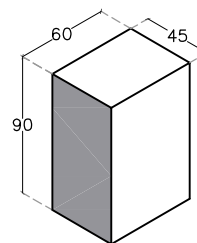

12 EXPRESSIONS IN CONTRASTS

A collage featuring fresh foliage, incorporated in a frame

Space allowed

Width : 75 cm

Depth : 18 cm

Height : 45 cm

Staging : To be placed on a wooden easel at 90cm from the floor. It may come over the front of the frame by 10 cm.

Maximum weight allowed is 4 kg.

The easel and the frame will be provided. A wire mesh will be attached to the frame at the back.

Colour of frame : Black

Colour of easel : Black

Backdrop : Silver Grey (Pantone 14-0000 TPG)

Viewed and judged from the front.

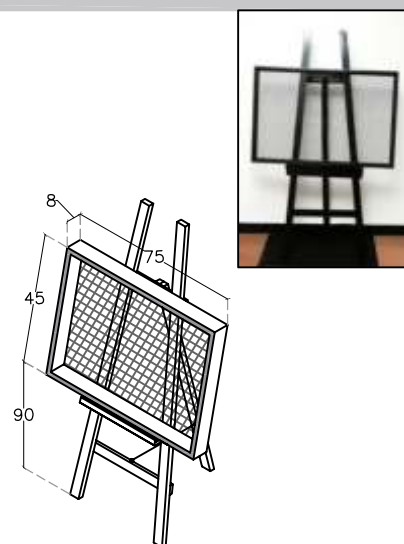

13 SPATIAL VISTA

An exhibit

Space allowed

Width : 60 cm

Depth : 45 cm

Height overall : 165 cm

Staging : Tabling 45 cm from the floor. A frame having a width of 60 cm, depth 45 cm, height 120 cm with 3 hooks at 30 cm distance on each side.

2 hooks on top 15 cm away from the edge. The frame is screwed to the centre of the table.

Height of backdrop : 180 cm

Colour : Backdrop and tabling is Silver Grey (Pantone 14-0000 TPG)

Viewed and judge from front.

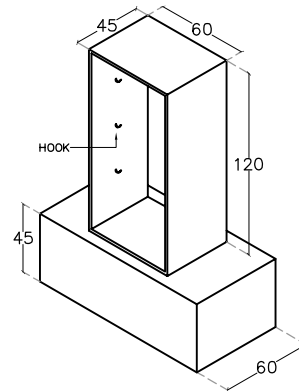

14 SAVAGE BEAUTY

An exhibit for an individual or a two person team

Space allowed

Width : 90 cm

Depth : 60 cm

Height overall : 180 cm

Staging : A wire mesh fixed on top of 4 iron rods height 180 cm. Each rod is fixed on a square iron base of 25 cm. Mesh size 2.5 cm

Mesh and rod colour : Silver Grey (Pantone 14-0000 TPG)

Maximum weight allowed : 8 kg

Not more than 2 kg at a point.

Viewed and judged from front and back.

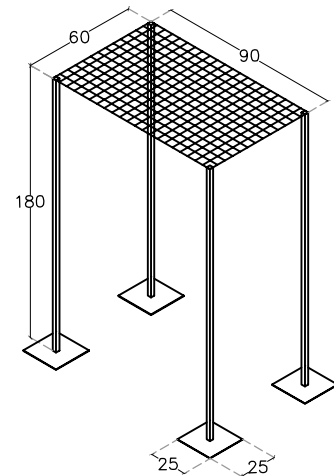

15 LET'S SPIN

Imposed Class

Space allowed

Width : 90 cm

Depth : 50 cm

Height overall : 165 cm

Staging : Tabling 75 cm from floor.

Colour : Silver Grey (Pantone 14-0000 TPG)

Viewed and judged from the front.

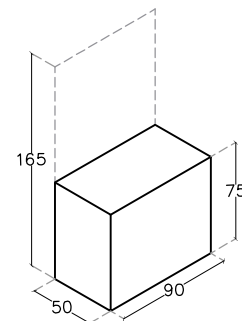

16 BIRD SONG

A miniature exhibit

Space allowed

- Width :** 10 cm
 - Depth :** 10 cm
 - Height :** 15 cm
 - Height overall :** 135 cm
 - Staging :** Tabling 120 cm from the floor
 - Colour :** Silver Grey (Pantone 14-0000 TPG)
- Viewed and judged from the front

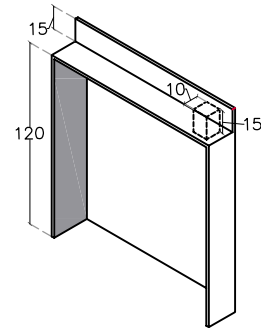

17 WEAVING SPELLS

Junior Craft Mail - in - Class - 10-15 years

Space allowed

- Width :** 30 cm
 - Depth :** 10 cm
 - Height :** 45 cm
- Staging :** The completed design should have 2 rings attached at the top at a distance of 7 cm from the two ends to be attached to the two hooks on the wall, 180 cm from the floor.
- Maximum weight allowed :** 750 gm
- Colour :** Silver Grey (Pantone 14-0000 TPG)
- Viewed and judged from the front.

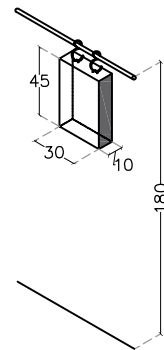

Open to WAFA and non WAFA junior members. To be brought in or mailed ready for staging by the show committee.

18 TREASURES OF THE EAST

Junior craft mail in class 15 -18 years

Space allowed

- Width :** 30 cm
 - Depth :** 15 cm
 - Height :** 30 cm
- Staging :** Tabling 120 cm from the floor having a depth of 40 cm. The self standing box to be placed 15 cm away from the edge of the table.
- Colour :** Silver Grey (Pantone 14-0000 TPG)
- Viewed and judged from the front.

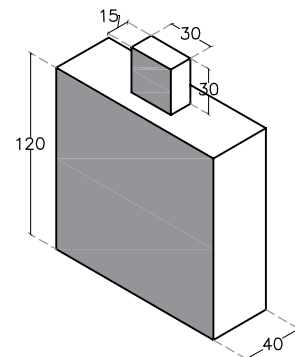

Open to WAFA & non WAFA juniors. To be brought or mailed ready for staging by Show Committee

19 DELICATE SPRING TIME

A petite design

Space allowed

Width : 45 cm

Depth : 45 cm

Height : 45 cm

Height overall : 165 cm

Staging : Tabling 120 cm from the floor. A square niche 45cm with an open top, having an arch on the front side.

Arch size : width 30 cm & height at centre 30 cm.

Colour of niche : Black

Table : Black

Viewed and judged from the front

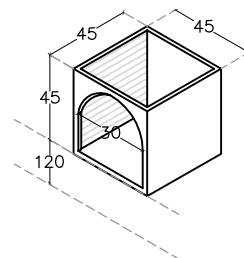

20 SUSPENDED SENSATION

An exhibit

Space allowed

Width : 60 cm

Depth : 60 cm

Height from floor: 180 cm

A hook will be provided at the centre of the rod.

Staging : A base 1.9 cm thick on the floor, each side being 60 cm.

Weight allowed 3.5 kg.

Colour of backdrop : Black

Viewed and judged from the front.

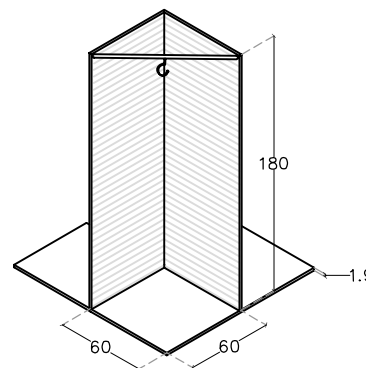

21 SOFT COMES THE MOON

A frieze- a frame to be incorporated

Space allowed

Width : 60 cm

Depth : 8 cm

Height : 45 cm

Frame to be brought by the competitor.

Staging :

Base - width 60 cm, depth 8 cm, height of back 180 cm.

Frame to be hung at 150 cm from the floor with 2 hooks at 10 cm from the two ends.

Frieze to be made within the borders of the frame.

Colour : Backdrop is Black

Viewed and judged from the front.

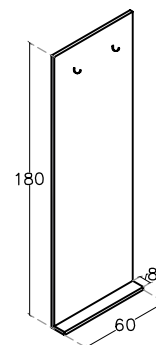

22 RICH TAPESTRY

Craft mail - in class

Space allowed

Width : 30 cm

Depth : 5 cm

Height : 45 cm

Staging : The completed design should be ready for hanging at the centre of the frame, from a hook attached to the wall, 140 cm from the floor.

Maximum weight allowed : 2 kg

Colour : Black

Viewed and judged from the front

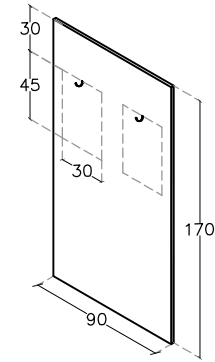

Open to WAFA & non WAFA members. To be brought in or mailed ready for staging by the show committee.

23 UPROOTED TOSSED AND TURNED

Imposed class

Space allowed

Width : 90 cm

Depth : 75 cm

Height overall: 180 cm

Staging : Tabling 75 cm from the floor.

Colour : Silver Grey (Pantone 14-0000 TPG)

Viewed from two sides and judged from front.

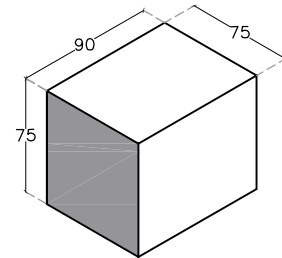

24 OF PALACES AND PEACOCKS

An exhibit for a 2 person team

Space allowed

Width : 120 cm

Depth : 75 cm

Height : 240 cm

Staging : A base 1.9 cm thick on the floor, width 120 cm, depth 75 cm and height 240 cm.

Colour : Backdrop and base is Silver Grey (Pantone14-0000 TPG)

A predone backdrop may be included in the design.

Viewed and judged from three sides.

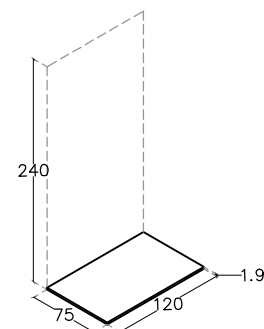

25 CIRCLES OF MYSTERY

An exhibit

Space allowed

Diameter : 75 cm

Height : Optional

Staging : A plinth width 30 cm, depth 30 cm, height 60 cm, with a circular top 75 cm in diameter .

Colour : Creme Brulee (Pantone 13-1006 TPG).

Viewed and judged from all around

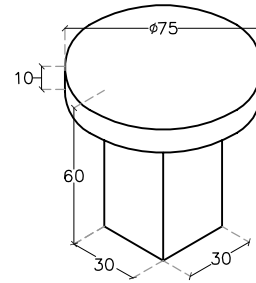

26 MONSOON MEMORIES

An exhibit

Space allowed

Width : 60 cm

Depth : 45 cm

Height overall : 180 cm

Staging : Height above tabling 60 cm, drop from tabling to floor 120 cm. Exhibit may extend down 100 cm but must not touch the floor. The design may come over the front of the table by 15 cm.

Colour : Backdrop and tabling is Creme Brulee (Pantone 13-1006 TPG)

Viewed and judged from the front.

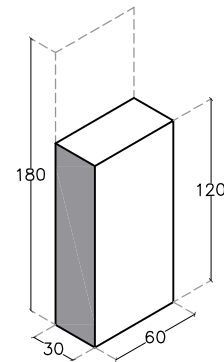

27 LAYER BY LAYER

Floor design

Space allowed

Width : 120 cm

Depth : 60 cm

Height : Optional

Staging : A centre metal pole height 150 cm, cross-section 3.5 cm X 3.5 cm, attached to a metal base 30 cm X 30 cm, 4 framed metal meshes attached at the centre.

Starting from top

Metal Mesh : width 30 cm, depth 10 cm, thickness 0.5 cm

Metal Mesh : width 90 cm, depth 10 cm, thickness 0.5 cm

Metal Mesh : width 60 cm, depth 10 cm, thickness 0.5 cm

Metal Mesh : width 30 cm, depth 10 cm, thickness 0.5 cm

Mesh placed at 23 cm distance from each other from the top.

Colour : Base and mesh : Black

Viewed and judge from all around

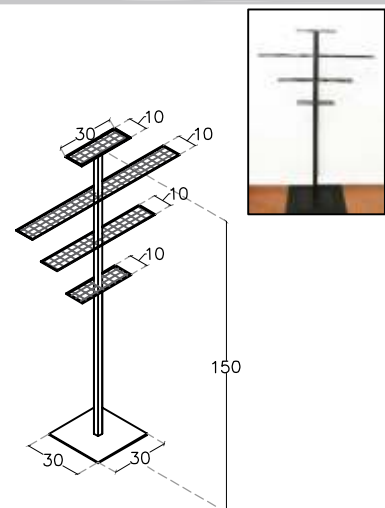

28 BEYOND THE FAR HORIZON

A landscape exhibit

Space allowed

Width : 90 cm

Depth : 90 cm

Height overall : 180 cm

Staging : Tabling at two levels

Level 1 : Width : 90 cm

Depth: 35 cm

Height : 75 cm

Level 2 : Width : 90 cm

Depth : 55 cm

Height : 90 cm

Colour : Backdrop and tabling is Silver Grey (Pantone 14-0000 TPG)

Viewed from all 3 sides and judged from the front.

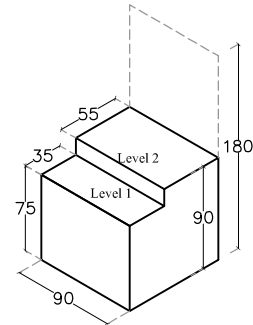

29 PEEK-A-BOO

Imposed class

Space allowed

Width : 90 cm

Depth : 60 cm

Height overall: 180 cm

Staging : Tabling 75 cm from the floor

Colour : Backdrop and tabling is Silver Grey (Pantone 14-0000 TPG)

Viewed and judged from the front

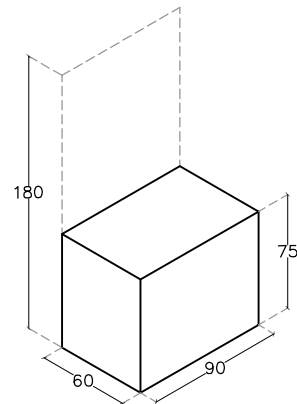

30 TRADERS OF ANTIQUITY

An exhibit

Space allowed

Width : 60 cm

Depth : 60 cm

Height overall : 180 cm

Staging : Tabling 90 cm from the floor.

Colour : Backdrop and tabling is Silver Grey (Pantone 14-0000 TPG)

Viewed and judged from the front.

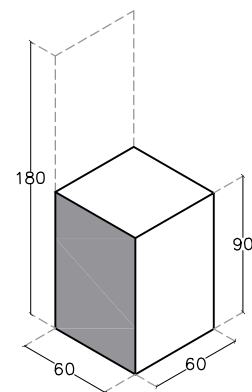



Staging :

Width : 120 cm

Depth : 120 cm

Height : 240 cm

Base Thickness : 1.9 cm

Colour : Backdrop and base is Creme Brulee
(Pantone 13-1006 TPG)

Viewed from the front.

Not to be judged.

By invitation.

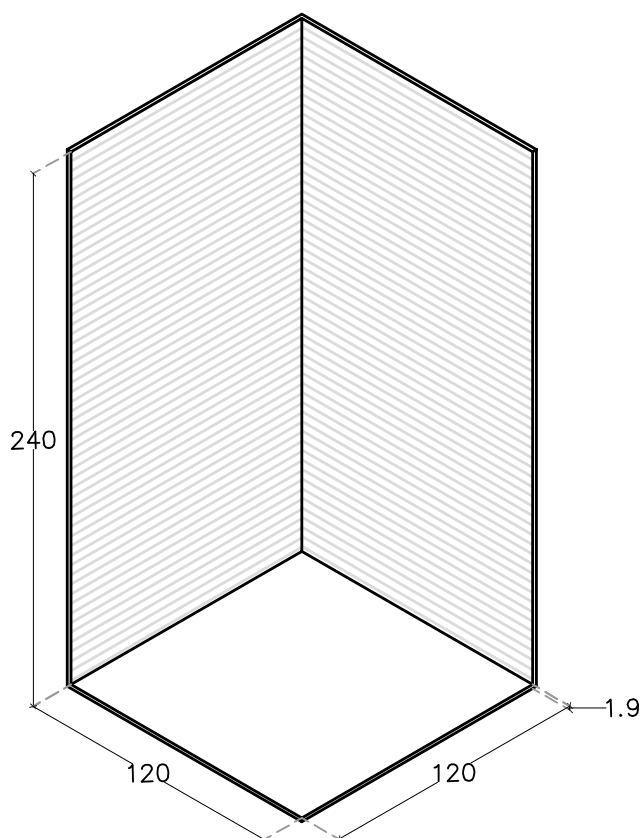

HOTEL AND TRAVEL INFORMATION



NAME	GOOGLE MAP LINKS	KMS FROM DIGGI PALACE	CATEGORY
Lords	https://goo.gl/maps/usrPp8tcTbt	0.3	3 Star
Grand Unaira	https://goo.gl/maps/cbJYEvdyfrm	2.7	3 Star
Park Prime	https://goo.gl/maps/KYFqE8FzEqA2	1.7	3 Star
Golden tulip	https://goo.gl/maps/vcCoXA7xKNt	1.6	3 Star
Polo Inn	https://goo.gl/maps/mfYZxR4UyNH2	0.7	3 Star
Shakun	https://goo.gl/maps/Rw6NBgiBmyv	2.1	3 Star
Grand Chankya	https://goo.gl/maps/Lvc6Y9NKMV12	0.9	3 Star
Hotel Mansingh	https://goo.gl/maps/PBsXwdMnPYx	3	3 Star
Lemon Tree Premier	https://goo.gl/maps/KPLj6D4z3tu	4.8	3 Star
Nirwana Homotel	https://goo.gl/maps/9g7znxehb3r	4.5	3 Star
Sawai Man Mahal	https://goo.gl/maps/pL5FC6Xgnhx	2.4	4 Star
Hilton	https://goo.gl/maps/dp3KR5whPhy	4.7	4 Star
Holiday Inn	https://goo.gl/maps/U5srw1DcwaG2	3.5	4 Star
Fortune Metropolitan	https://goo.gl/maps/z3wEsNkgJ3S2	3.4	4 Star
Taj Rambagh Palace	https://goo.gl/maps/oiMeqLJNnap	3.5	5 Star
Taj Jai Mahal Palace	https://goo.gl/maps/k6TUQzrE7z32	4.4	5 Star
Sujan Raj Mahal Palace	https://goo.gl/maps/Hap3sLoBCV12	4	5 Star
Narain Niwas	https://goo.gl/maps/PgfNVSrLEq52	3.4	Heritage
Clarks Amer	https://goo.gl/maps/4uXjkyJrLf42	9.7	5 Star
Jaipur Marriott	https://goo.gl/maps/T3fmmPFtDNU2	11	5 Star

► **Mr. Sourabh Sharma (+91 9660740111) | Company Name: Herit'edge | Email: sales@heritedge.co.in**

► **Mr. Manoj Bhatt (+91 9799444111 / 8005778924) | Company Name: Royal Rajasthan Tours
Email: royalsrajasthantours@gmail.com / inquiry@royalsrajasthantours.com**

COME, LET'S HAVE FUN WITH FLOWERS

A variety of activities, demonstrations and workshops will be conducted by us in order to showcase Indian art and craft. We are looking forward to spread friendship through flowers.





PUSHPA BITAN FRIENDSHIP SOCIETY

Pushpa Bitan Friendship Society the INDIAN representative of WAFA who actively promotes the art of flower arrangement and floral design through workshops, seminars and flower shows. It conducts classes and organizes demonstrations of various floral art forms. World Floral Art experts & instructors are regularly invited to train our members. They travel all over the world taking active part in competition, workshops, exhibitions, etc. We have active chapters in Jaipur & Dubia too.

Address:-

Pushpa Bitan Kolkata:-
Shree Anjali 37/1 C Hazra Kolkata, West Bengal 700019
E-mail : pushpabitan786@gmail.com

Follow us on:-

<https://wafaindia.com>
<https://www.facebook.com/PushpaBitanJaipur>
https://www.instagram.com/pushpa_bitan
<https://www.instagram.com/pushpabitan/>

Every *Form* of the competition
has to have your name on top!

The *Colour* of your flag will
Fly High & make your dream
come true.

The *Rhythm* is to make
not to break.

Proportion of your success depends on
innovation & practice.

Dominance be careful
not to be called the Nagging life.

Be in the *line* of winner
A great place to be in.

Make sure your design tips the
Balance in your favour.

Create your *Space*
among the Toppers.

Do it with *Harmony*
never create discord

Shape your destiny
Its in your Hands!

